

# MAASS™ Model JS-B Adapters

For Sewage, Waste and Sump Pump Installations

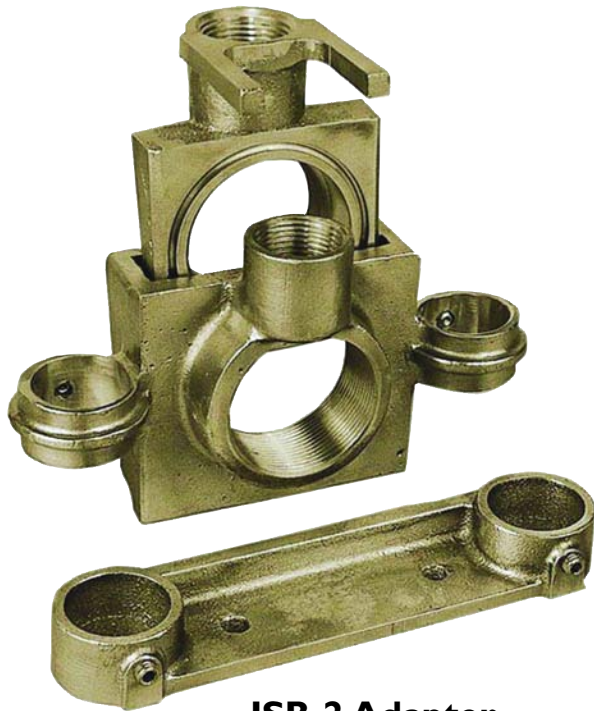

**JSB-2 Adapter**

**MAASS JS ADAPTERS ARE IDEAL** for use in sewage basins, pressurized sewage systems, cisterns and sump pump installations.

- Allows for easy service to any submersible pump installation.
- All Naval Brass\* construction to defeat rust, corrosion and electrolysis.
- Safe to use. Not necessary to climb into effluent tank to disconnect pump, risking danger of asphyxiation.
- Not necessary to pump tank to service pump.
- Brass insert with pump attached slides down 1" guide pipe (furnished by installer) into an all brass housing. Two matching 8 degree non-locking taper wedge parts (on both insert and housing) force O-ring in brass insert against brass machined housing for complete seal.
- No wires, nuts, levers, or triggers needed to complete seal or remove pump. A simple slip fitting does it.

## JSB-2

- 2" NPT inlet and outlet
- 1" pipe used for guides and supports.

\*Naval Brass is a superior brass for resisting the corrosive effects of chlorides and sulphates generally found in sewage effluents.

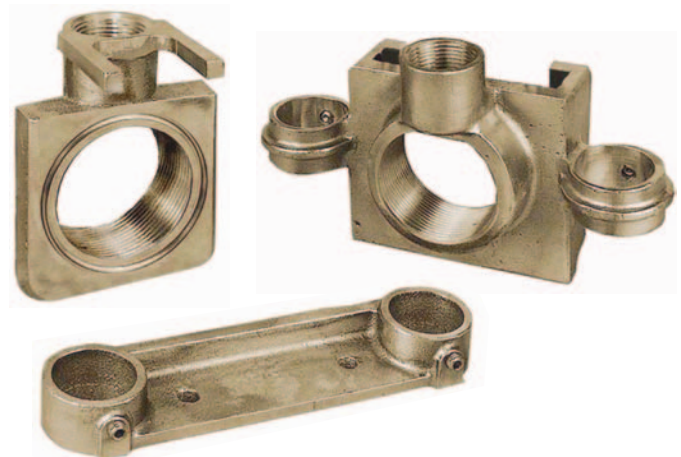

©2011, MAASS Midwest Manufacturing, Inc.



**MANUFACTURERS OF QUALITY WATER WELL ACCESSORIES**

U.S. & CANADA 1-800-323-6259 • FAX 1-847-669-3230 [www.maassmidwest.com](http://www.maassmidwest.com)

P. O. Box 547, 11283 Dundee Road, Huntley, IL 60142-0547 • (800) 323-6259 • IL AREA (847) 669-5135

MEMBER:



# Model JSB-2" SEWAGE ADAPTER

MADE in the USA 

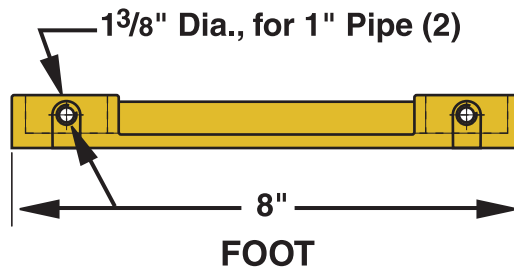
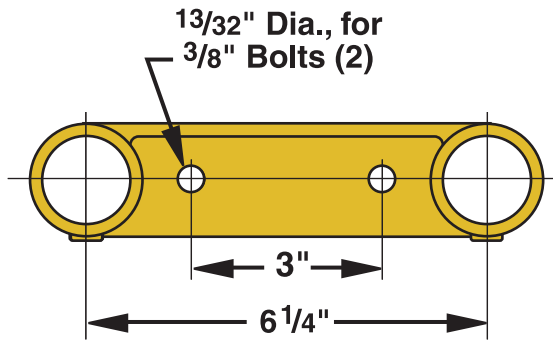
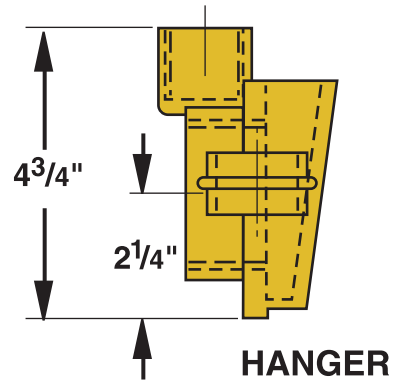
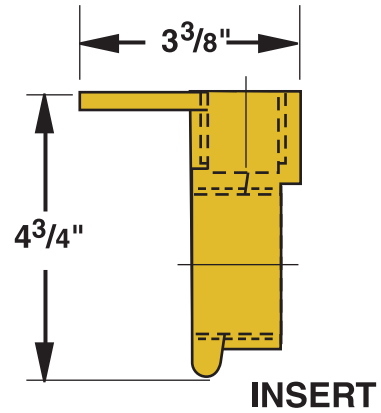
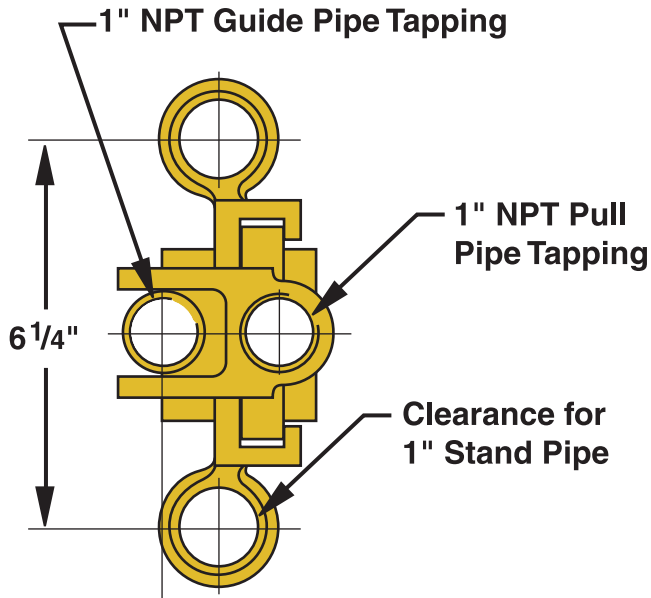

©2011, MAASS Midwest Manufacturing, Inc.



**MIDWEST**

**MANUFACTURERS OF QUALITY WATER WELL ACCESSORIES**

U.S. & CANADA 1-800-323-6259 • FAX 1-847-669-3230 [www.maassmidwest.com](http://www.maassmidwest.com)

P. O. Box 547, 11283 Dundee Road, Huntley, IL 60142-0547 • (800) 323-6259 • IL AREA (847) 669-5135

MEMBER:



# MAASS™ Model JSB Sewage Adapters

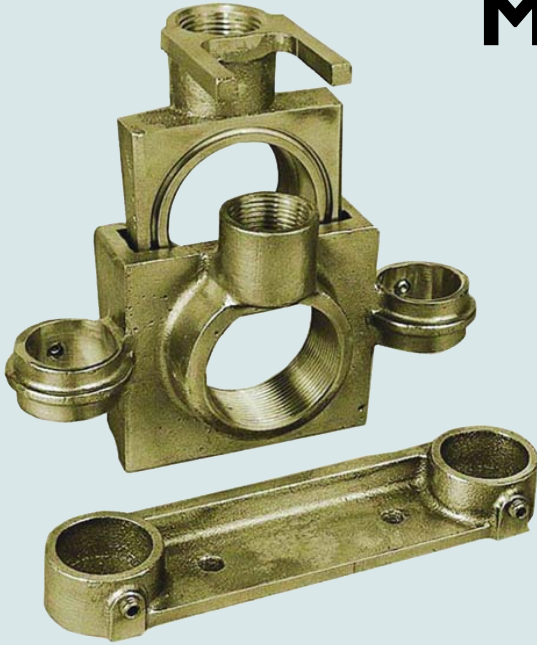

## FEATURES:

- ✓ Large 8° Taper Slide for ease of installation or removal
- ✓ 2" NPT inlet and outlet
- ✓ 1" pipe used for guides and support
- ✓ 100% naval brass construction for corrosion resistance
- ✓ Allows easy service to any submersible pump installation
- ✓ Not necessary to pump tank to service pump

| Part Number | Model Number | NPT Size |
|-------------|--------------|----------|
| 928980      | JSB-2        | 2        |

## Sewage Adapter Brackets



### JSB-2 Stand Off Bracket

#### FEATURES:

- ✓ 304 stainless steel to resist corrosion
- ✓ Easily installed beneath septic tank lid or off the wall
- ✓ Utilizes (2) 1/2" bolts for mounting

| Part Number | For Model Number | Mounting Holes |
|-------------|------------------|----------------|
| 928985      | JSB-2            | 9/16"          |

### JSB-2 Universal Stand Off Bracket



#### FEATURES:

- ✓ 19" overall length allows adjustment every 4 1/2"
- ✓ Durable two part epoxy coating
- ✓ Utilizes (2) 1/2" bolts for mounting

| Part Number | For Model Number | Mounting Holes |
|-------------|------------------|----------------|
| 928995      | JSB-2            | 9/16"          |



MADE in the **USA**



MANUFACTURERS OF QUALITY WATER WELL ACCESSORIES

©2011, MAASS Midwest Manufacturing, Inc. All rights reserved.

# MAASS™ Model JSB Sewage Adapters

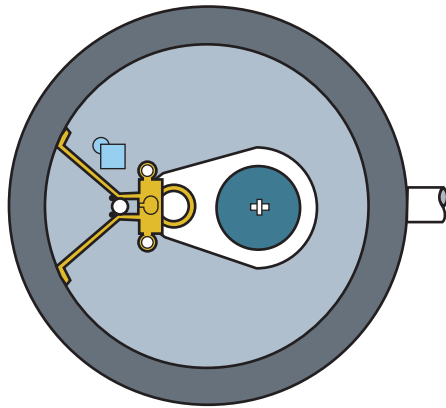

**NOTE:**

1. Schedule 80 PVC or stainless steel pipe is recommended throughout.
2. For stand, guide and lift pipe, use 1" pipe for model JSB-2. Use 1.4" pipe for Model JSB-3 Sewage Adapter.
3. The material used in the series JSB Sewage Adapters is cast Navy Brass.

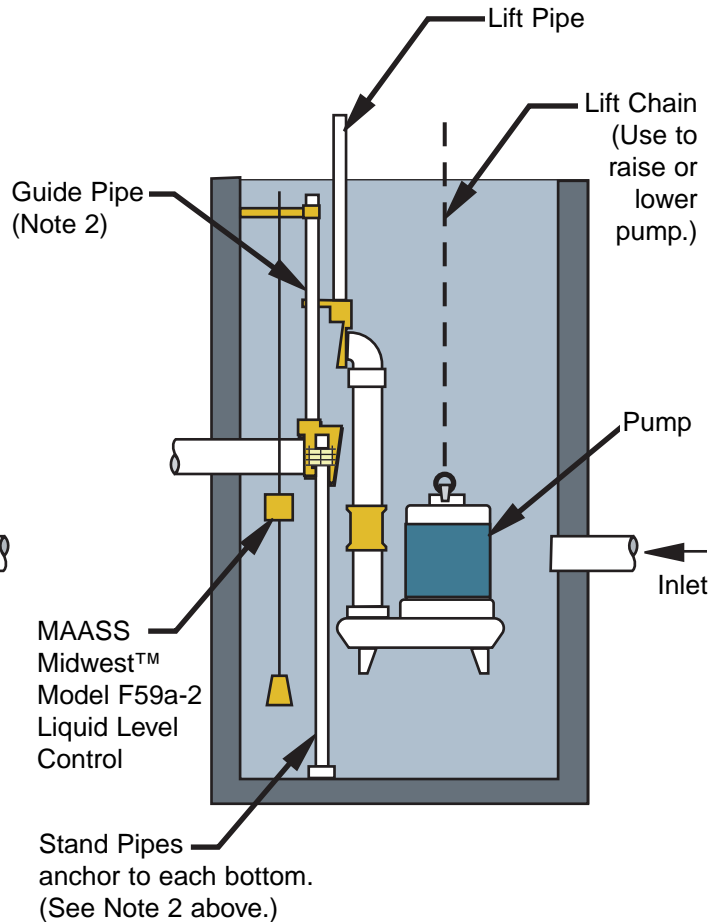
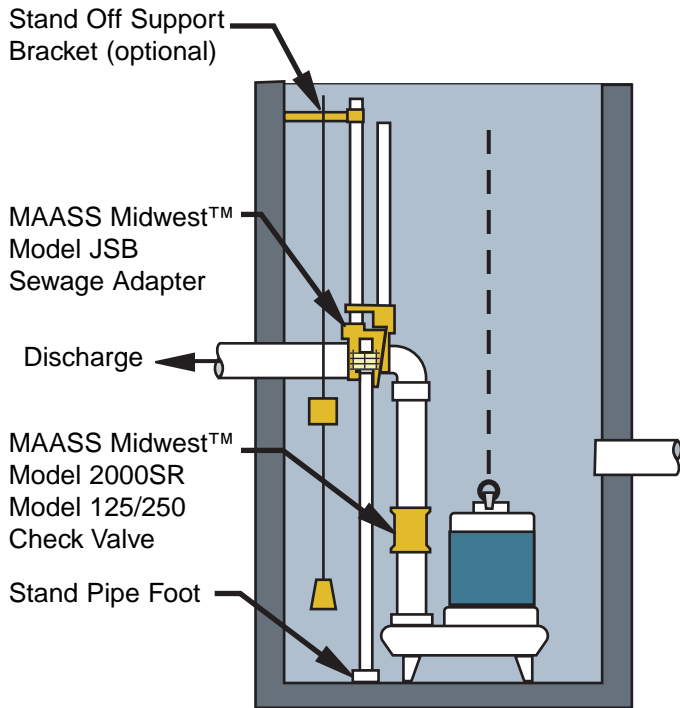

©2011, MAASS Midwest Manufacturing, Inc.



**MANUFACTURERS OF QUALITY WATER WELL ACCESSORIES**

U.S. & CANADA 1-800-323-6259 • FAX 1-847-669-3230 [www.maassmidwest.com](http://www.maassmidwest.com)

P. O. Box 547, 11283 Dundee Road, Huntley, IL 60142-0547 • (800) 323-6259 • IL AREA (847) 669-5135

MEMBER:



MAASS Midwest is a member of the National Groundwater Association and the Water Systems Council.