

NEW! **Universal Hydrant "Drain Box"**

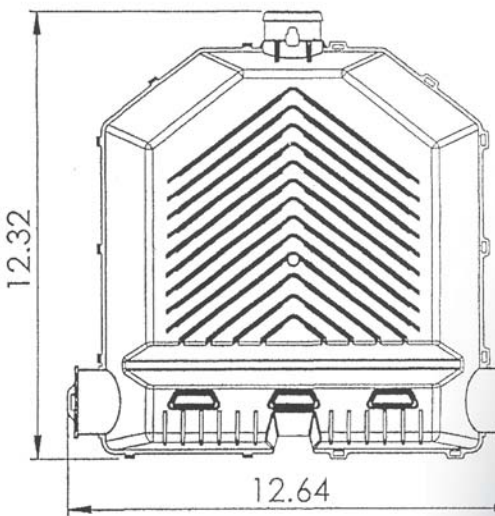

MADE in the USA



Features:

- Eliminates gravel pack
- Provides drainage away from valve body
- External louvers retain soil from entering upper valve body
- Openings on sides and bottom allows water to percolate into ground
- Drainage equivalent to nine square feet of washed gravel, six inches thick
- 100% Recycled Material

Any bury depth frost-free hydrant

Hose Clamp X3

Drain Oriface

Water Drain Louvers

Locking Tabs

Structural Ribs

Soil impediment plate

T or 90° Connector

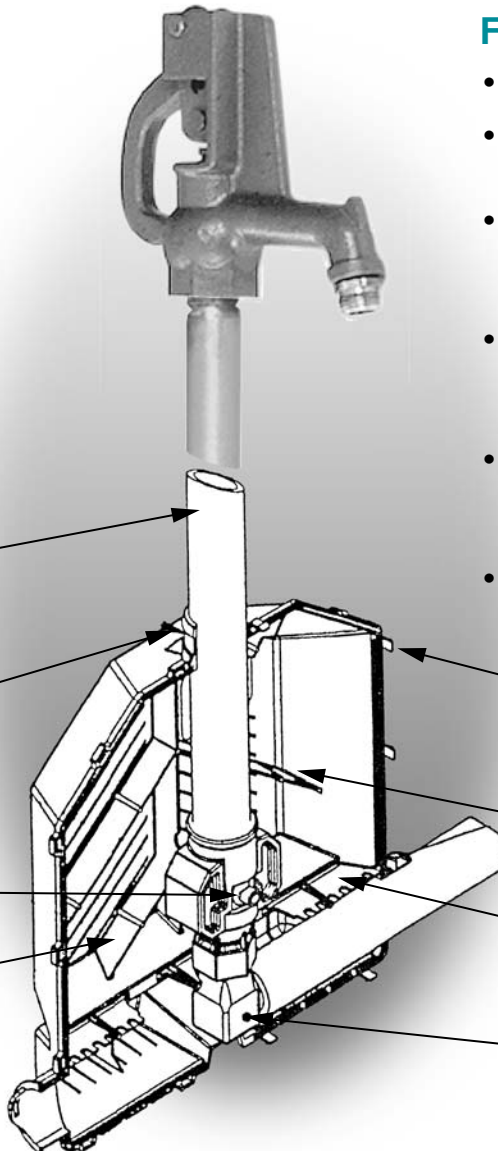

Part Number	Weight	List Price U.S. Funds
935350	2.0#	\$53.86

*Includes 3 Clamps

MEMBER:



LISTED PAS-97(04)
PULSED ADAPTER STANDARD